

Cable Ties

Screw Mounted

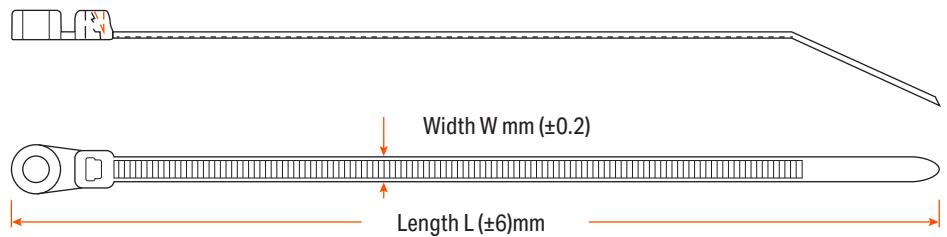

- **Material:** UL approved Nylon 66, 94V-2.
- **Application:** The cable tie can be secured to a panel using a single screw.
- **Operating Temperature:** -40°C to +85°C.

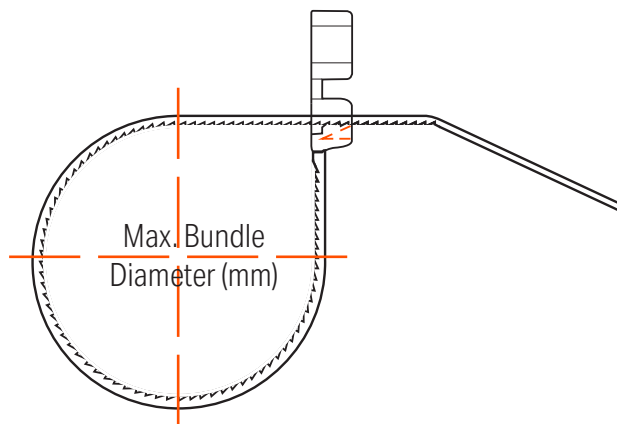

Cable Ties

Screw Mounted

Item No.	Colour	Width W (mm)	Length L (mm)	Screw	Max. Bundle Diameter (mm)	Min. Tensile Strength (kg)
SCT1-B	Black	2.5	110	M3	25	8
SCT2-B	Black	3.7	171.5	M4	36	18
SCT3-B	Black	4.8	200	M5	52	22
SCT4-B	Black	4.8	300	M5	85	22
SCT5-B	Black	4.8	370	M5	102	22
SCT6-B	Black	7.8	300	M5	85	54
SCT7-B	Black	7.6	400	M6	112	54
SCT1-N	Natural	2.5	110	M3	25	8
SCT2-N	Natural	2.5	150	M4	36	18
SCT3-N	Natural	4.2	219	M5	52	22
SCT4-N	Natural	4.8	300	M5	85	22
SCT5-N	Natural	4.8	370	M5	102	22
SCT6-N	Natural	7.6	300	M5	85	54
SCT7-N	Natural	7.6	400	M6	112	54

STORAGE AND USAGE OF NYLON CABLE TIES

BEAL UK cable ties are made from high quality Nylon 66 resin. Moisture absorption is an essential factor for this material to retain its strength and maintain optimal performance. To this end, it is important for the cable ties to be kept in a sealed package wherever possible.

Below are some helpful storage suggestions:

1. The ideal storage temperature is around 23°C with the humidity over 50%.
2. Do not open the bag before use. Please try to finish the whole package of cable ties shortly after opening or reseal the bag until you are ready to use again.
3. Do not expose directly under sunlight (except UV weather resistant cable ties).
4. Avoid storing cable ties close to warm objects (such as heaters).